

Grade 1 / Graad 1: Week 5 & 6

English / Afrikaans



Houses / Huise



Ministry of Education,
Arts and Culture



NAMIBIAN
COMMUNITY TRUST

unicef 
for every child



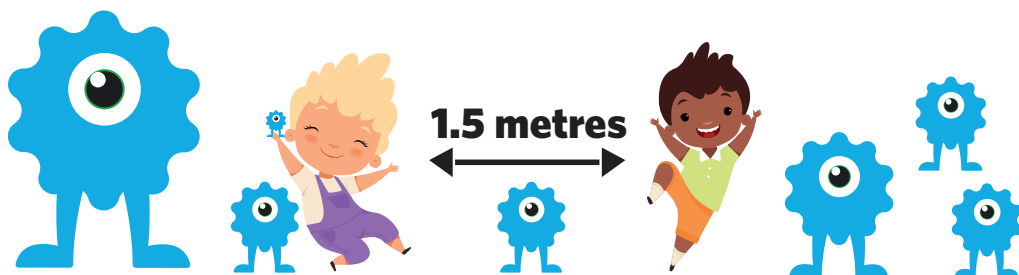

These numbers indicate which day you can complete each worksheet! But if you want to, you can work ahead and do the rest as well.

This publication is a collaboration between the Ministry of Education, Arts and Culture and Namibia Media Holdings. This publication is sponsored by the Ministry.

Copyright © Ministry of Education, Arts and Culture. All parts of this publication cannot be reproduced, stored in a retrieval system or transmitted in any form or by any means, electronic, mechanical, photocopying, recording or otherwise without prior permission of the Ministry of Education, Arts and Culture or the Publisher.

Production by: Namibia Media Holdings **NMH** NAMIBIA MEDIA HOLDINGS

Printing: Newsprint Namibia **newsprint** NAMIBIA



Vocabulary / Woordeskat

blow

blaas

run

hardloop

straw

strooi

Read and trace the vocabulary words:
/ Lees en skryf die woordeskat woorde:

blow

blaas

blow

blaas

run

hardloop

run

hardloop

straw

strooi

straw

strooi

Unscramble the letters to build words (English only)

nur _____

wlob _____

wastr _____

Search the following words: run, blow, straw (English only)

s	t	r	a	w
a	e	u	p	l
i	o	n	m	n
b	l	o	w	h

Ordering and comparing / Ordening en vergelyking

Arrange the numbers in order from the smallest to the biggest: /
Rangskik die getalle van kleinste na grootste:

Example/Voorbeeld: 5 4 2 7

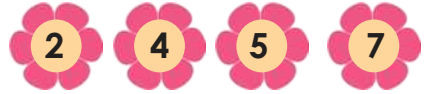

a) 9 1 3 6



b) 2 9 8 4

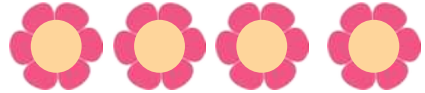

c) 3 10 2 8

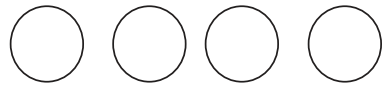

d) 6 5 2 9

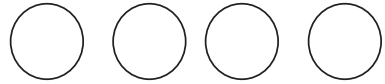

Circle the small number: / Omkring die klein nommer:

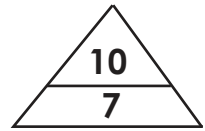
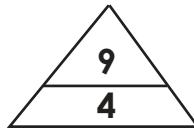
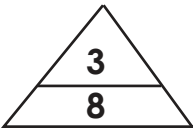

Cross out the bigger number: / Maak 'n kruis op die groter
nommer:

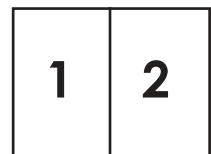
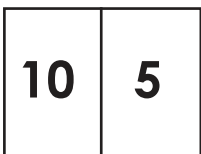

Write the correct personal pronoun: we / I/ you/ it/ he/ they/ she.

Skryf die regte persoonlike voornaamwoord: ek/ ons/ jy/hulle/dit/sy/hy.



_____ am Maria.

_____ is Maria.



_____ are Pam.

_____ is Pam.



_____ is Sam.

_____ is Sam.



_____ is Ann.

_____ is Ann.



_____ is a pen.

_____ is 'n pen.



_____ are Mary and Tom.

_____ is Mary en Tom.



_____ are Rose and Victor.

_____ is Rose en Victor.



_____ are Any and Memo.

_____ is Amy en Memo.





English / Afrikaans

Sight words / Sigwoorde

Read and trace the sight words: / Lees en trek die sigwoorde op die stippellyne:

in

in in

it / dit

it dit

Circle the windows with the sight words in it:

Omkring die venster met die sigwoorde in:

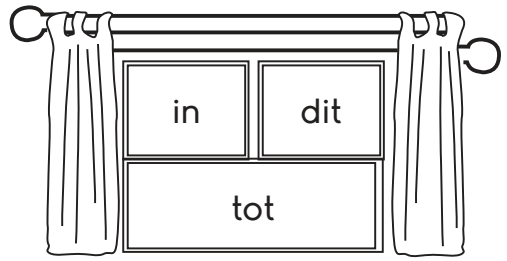
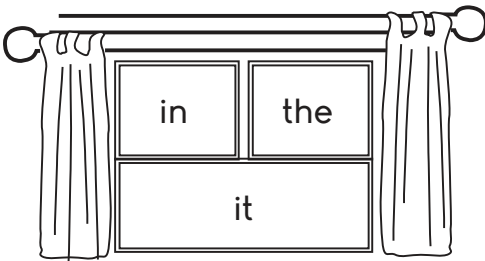

Fill in the correct word (in / it):

The ball is _____
the box.

My pen is lost. I can't find
_____.

I am in _____
Grade 1.

_____ is my bag.

Vul in die regte woord (in / dit).

Die bal is _____
die boks.

My pen is weg. Ek kan
_____ nie
kry nie.

Ek is

Graad 1.

_____ is my sak.

The Number 5 / Die Nommer 5

Color 5 images / Kleur 5 prente in

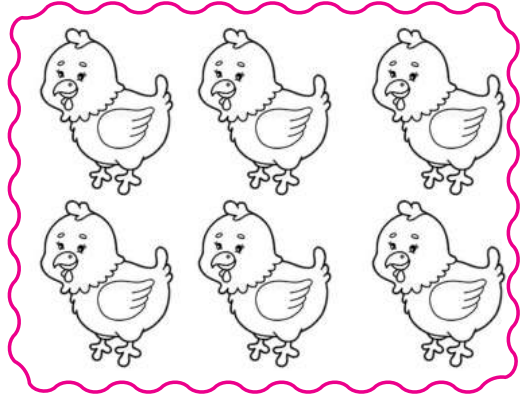

Week 5

Grade 1

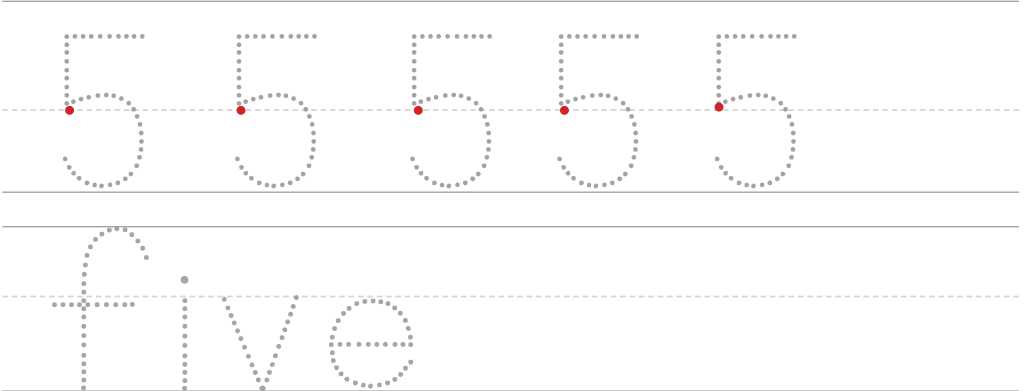

Circle the box with five images /
Omkring die boks met vyf prente

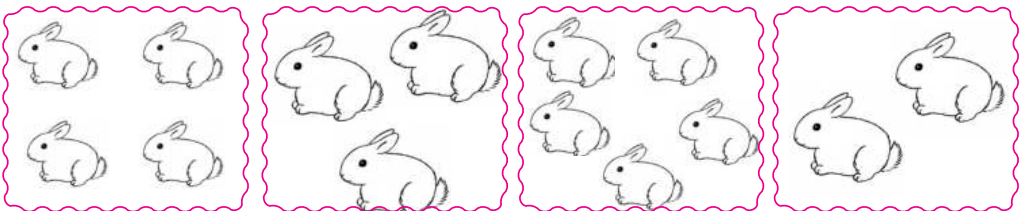

English / Afrikaans

Read the story and answer the questions. /
Lees die storie en beantwoord die vrae wat volg.

English: Who? What When?

My mom was teaching me. I was doing homework.
I completed my homework at 7 o'clock.

Who was teaching me?

- a) Ann b) Sam c) Mom

What was I doing?

- a) Painting b) playing c) homework

When did I complete my homework?

- a) 7 o'clock b) 4 o'clock c) 3 o'clock

Afrikaans: Wie? Wat? Wanneer?

My mamma het my geleer. Ek het my huiswerk gedoen. Ek het my huiswerk 7uur klaar gemaak.

Wie het my geleer?

- a) Ann b) Sam c) Mamma

Wat het ek gedoen?

- a) Verf b) Speel c) huiswerk

Wanneer het ek my huiswerk klaar gemaak?

- a) 7uur b) 4uur c) 3uur



English / Afrikaans

Odd and even numbers/ Ewe en Onewe getalle

Colour the candy hearts according to the colour code. / Kleur die harte in volgens die kleur-kode.

How many / Hoeveel

even / ewe



odd / onewe

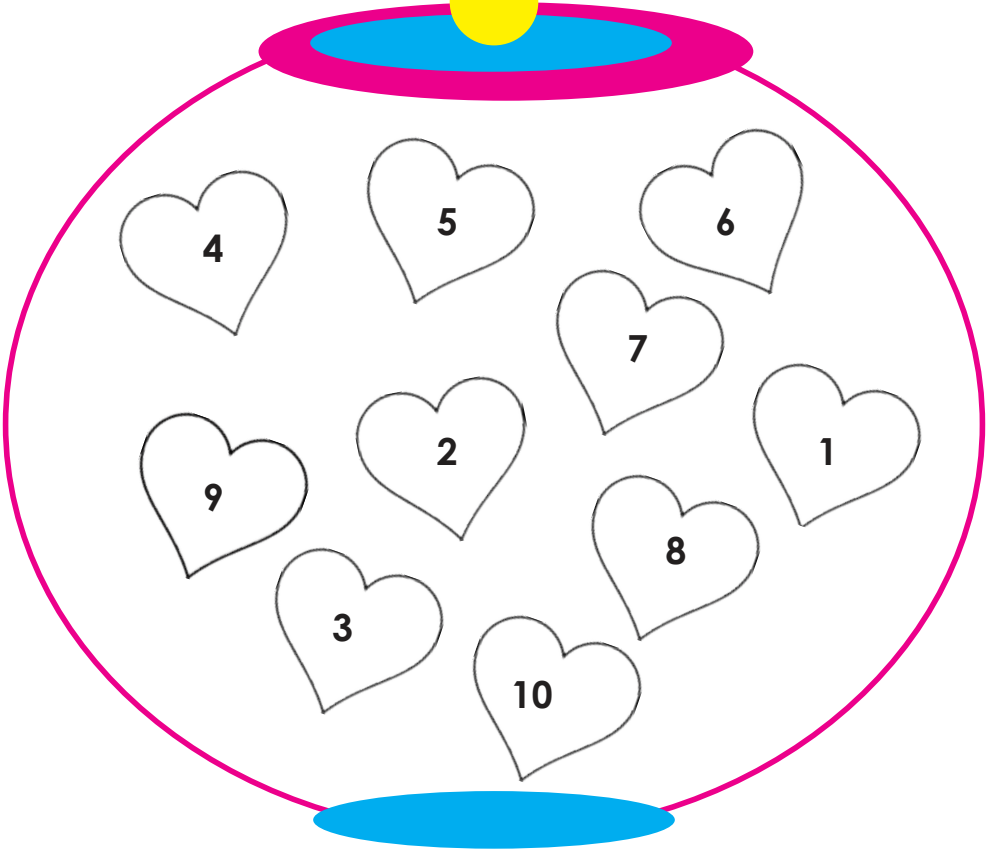

Week 5

Grade 1

How many hearts are in the jar? /
Hoeveel harte is in die potjie?



1.5 metres



English / Afrikaans

Possessive pronouns /
Besitlike voornaamwoorde

Read the words / Lees die woorde

Pronoun / Voornaamwoord

I	ek
you	jy
he	hy
she	sy
it	dit
we	ons
they	hulle



Possessive pronoun / Besitlike voornaamwoorde

mine	myne
yours	joune
his	syne
hers	hare
it's	dit
ours	ons s'n
theirs	hulle s'n



Doubling / Verdubbel

Example

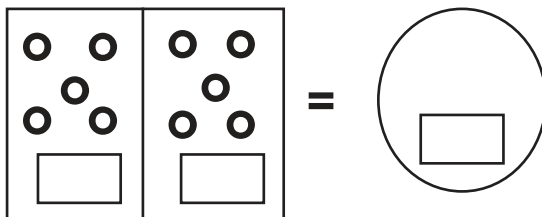
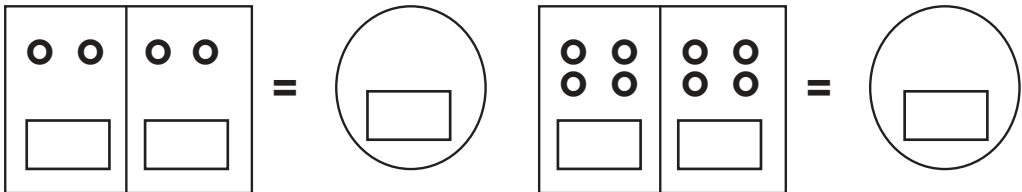
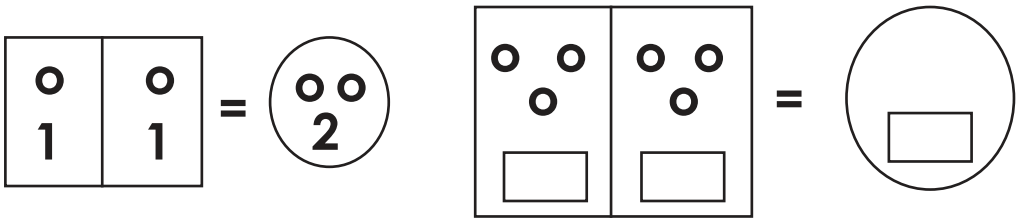

I have 2 doors. Mother gives me 2 more doors.

How many doors are they altogether?/

Ek het 2 deure. Mamma gee vir my nog 2 deure.

Hoeveel deure is daar altesaam?

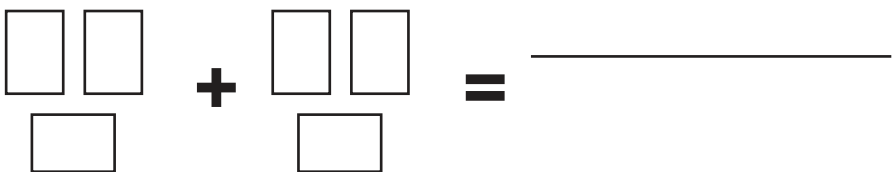

Three little pigs / Die 3 varkies

Number each picture to put the story in order. Retell the story in your own words. / Nommer elke prent om die storie in orde te sit. Vertel die storie in jou eie woorde.

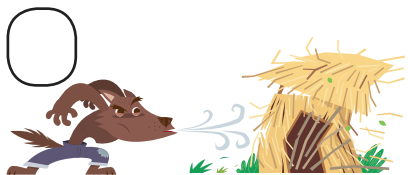







Colour in / Kleur in

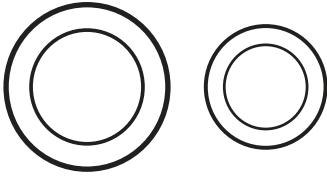

Colour in / Kleur in

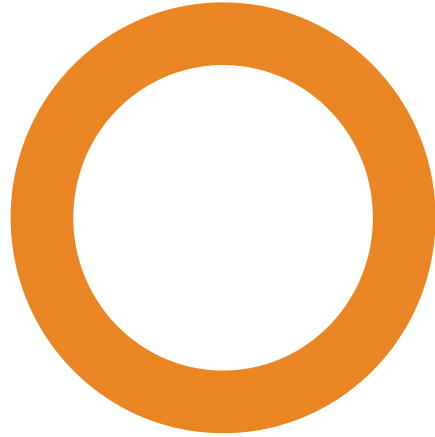

Orange / Oranje

O o c C b Q o O
 Q O a a O a D d
 o D O a d o O Q

Circle the letter O /
 Omkring die letter O

Trace / Trek op die stippellyn

Write / Skryf

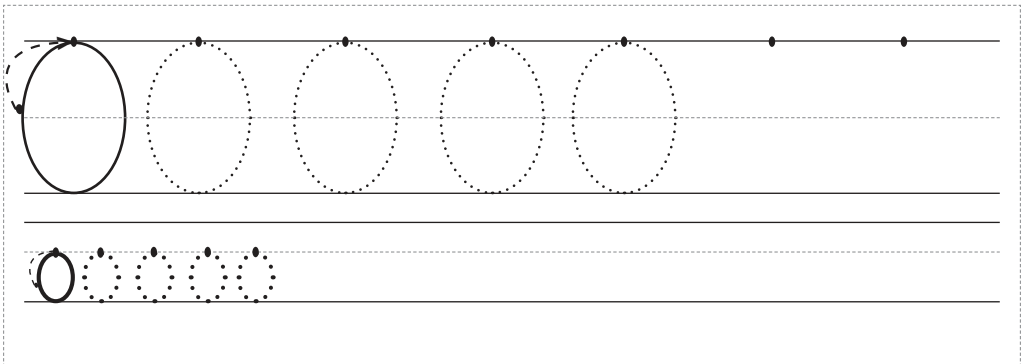

- J - K - L -

- M - N - O -

- P - Q - R -

Trace / Trek op die stippellyn

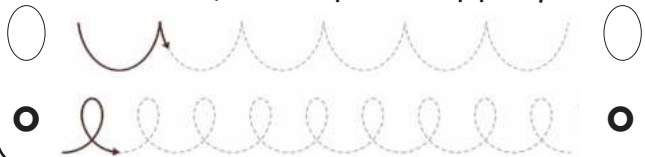

English Activity

Possessive pronouns

They have a car.



_____ car is red.

my
his
their
our
your

Lisa has two friends.



_____ friends are funny.

her
your
its
our
my

You have an umbrella.



_____ umbrella is big.

my
your
his
her
its

We have a book.



_____ book is funny.

his
her
its
our
their

The teacher has a pencil.



_____ pencil is big.

my
her
its
our
their

You have a present.



_____ present is big.

his
her
your
our
their

The bear has a guitar.



_____ guitar is small.

our
their
my
his
its

I have got a ball.



_____ ball is new.

his
her
its
our
their



English / Afrikaans

Mass / Massa

Circle the heavy object: / Omkring die swaar voorwerp:

feather	cup
---------	-----

glue	worm
------	------

bus	butterfly
-----	-----------

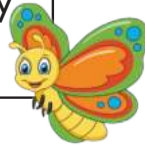

elephant	leave
----------	-------

Week 5

Cross out the heavier object. /
Maak n kruis op die swaarder voorwerp.



book	pencil
------	--------

worm	apple
------	-------

table	chair
-------	-------

5 kg sugar	1 kg sugar
------------	------------

Grade 1

The wise and the foolish man /
Die wyse en dwaase man.

Colour in the picture. / Kleur die prent in.

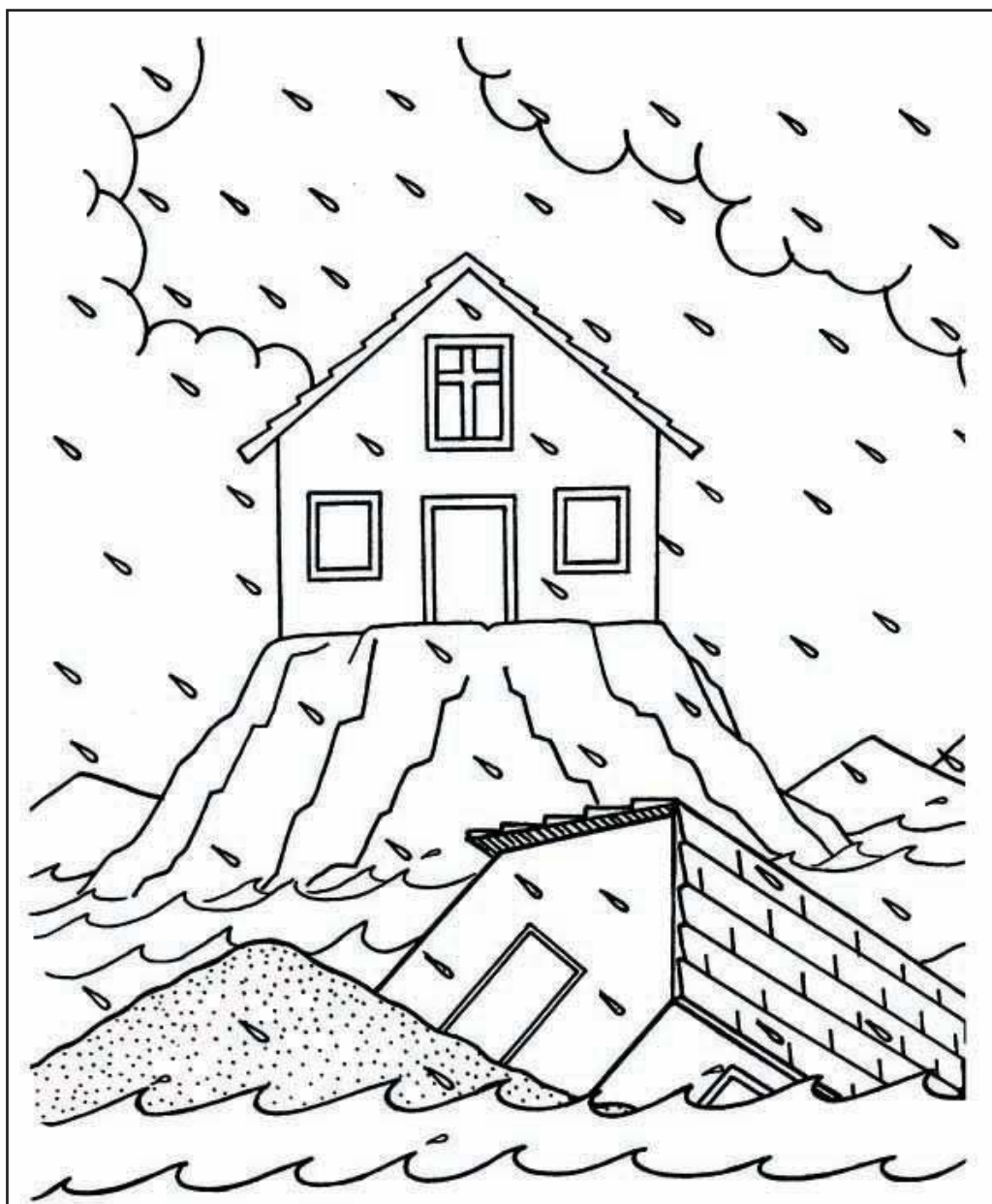

Vocabulary / Woordeskat

Read it/ Lees dit:

Trace the words/ Skryf die woord:

huff	huffel
build	bou

huff	huffel
build	bou

Complete the word: / Voltooi die woord:

huff	blaas	h _ f _ _	b _ a _ s
build	bou	b _ i _ d	b _ u _

Unscramble the letters

Rangskik die letters:

fhuf	fflehu
dliub	obu

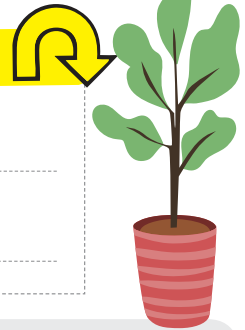

Fill in the correct word: huff, build:

The wolf and puff.

The bird a nest.

Vul die regte woord in: huffel en bou:



Die wolf en blaas.

Die voël 'n nes.



English / Afrikaans

Addition/ Plus

Count the objects, write the numbers and find the sum total. /
Tel die prente, skryf die nommers en vind die som total.

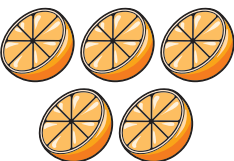

	+		=	4
---	---	---	---	---

	+		=	
---	---	---	---	--

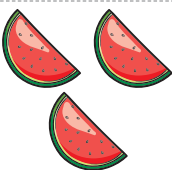
	+		=	
--	---	--	---	--

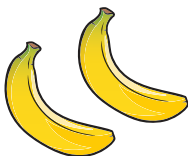
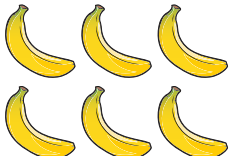
	+		=	
---	---	---	---	--

	+		=	
---	---	---	---	--

	+		=	
---	---	---	---	--



English / Afrikaans

The 'p' sound / Die 'p' klank

Colour in/ Kleur in

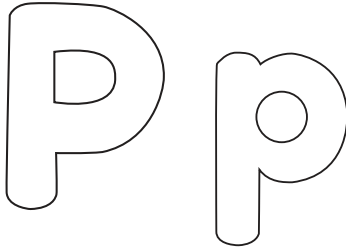

Colour in/ Kleur in

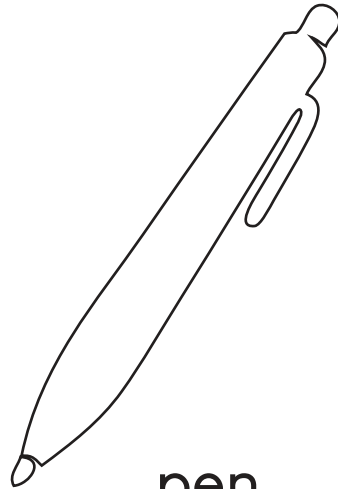

pen

Circle the letter 'p' /
Omkring die 'p':

p P b p B b P
b B p P b P B p
p P d p b p d

Week 6

Grade 1

Trace/Trek op die stippellyn

Write/Skryf

Tracing practice for uppercase 'P' and lowercase 'p' on a four-line grid. The first row shows four dotted uppercase 'P's with a stroke order diagram (1: vertical down, 2: curve) for the first one. The second row shows four dotted lowercase 'p's with a stroke order diagram (1: counter-clockwise circle, 2: vertical down) for the first one. The remaining lines are blank for writing practice.

Trace/Trek op die stippellyn

- M - N - O -
- P - Q - R -
- S - T - U -

Tracing practice for cursive letters. The top row shows a dotted uppercase 'P' followed by a series of connected cursive loops and ends with a dotted uppercase 'P'. The bottom row shows a dotted lowercase 'p' followed by a series of connected cursive loops and ends with a dotted lowercase 'p'.

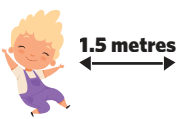

English / Afrikaans

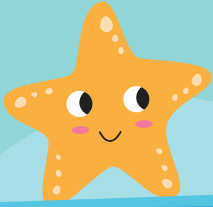
Sightwords/
Sigwoorde

Read it! / Lees dit!

Trace the words! / Skryf dit!

to

tot

my

my

one

een

two

twee

three

drie

in

in

it

dit

to

to

tot

tot

my

my

my

my

one

een

two

twee

three

drie

in

in

in

in

it

it

dit

dit

Word search



t	n	r	e	i	e	w	u	j
h	k	t	n	t	q	f	e	r
r	o	w	e	o	r	o	n	o
e	k	o	j	m	y	o	f	r
e	n	q	u	p	f	p	n	i
w	r	k	w	o	e	t	r	n
o	n	e	o	f	u	o	e	r

The Number 6. / Die Nommer 6.

1 2 3 4 5 6 7 8 9 10

Trace / Trek

Colour to show 6: / Kleur in om 6 te wys:

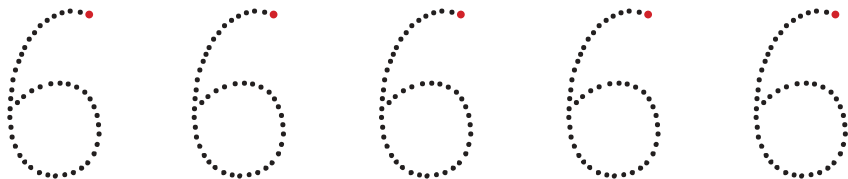

Colour the pictures that show 6: / Kleur die prente wat 6 wys in:

Write the 6 in the open space: / Skryf die 6 in die oop spasie:

Week 6

Grade 1

English / Afrikaans

Where and What? / Waar en Wat?



I have a cat.
What do I have?

Ek het 'n kat.
Wat het ek?

Mom loves chocolate.
What does mom love?

Dad drives to town.
Where is dad driving?

Mamma is lief vir sjokolade.
Wat is mamma lief om te eet?

Pappa ry dorp toe.
Waarheen ry Pappa?



Tim goes to school.
Where is Tim going?

Tim gaan skool toe.
/ Waar heen gaan Tim?



English / Afrikaans

Data handling. / Datahantering.

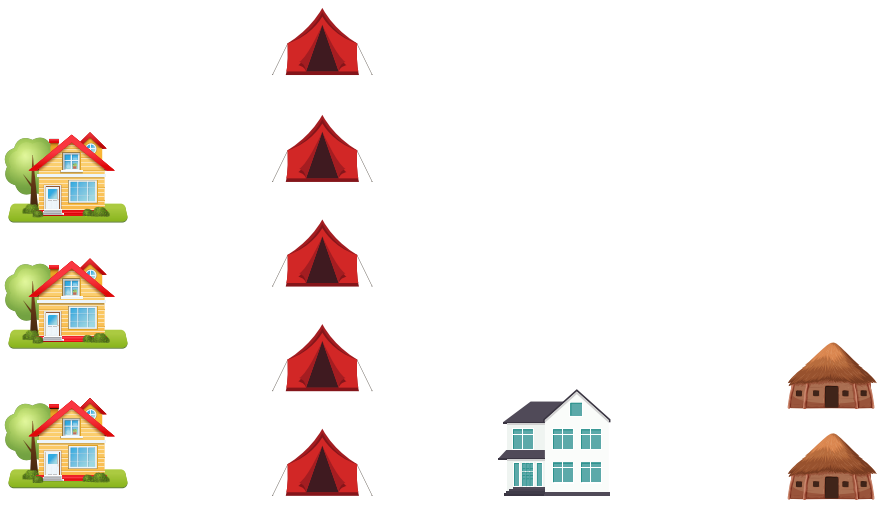

houses:
huise

tents:
tente

flats:
woonstelle

huts:
hutte

Week 6

Grade 1

Count how many of each:

houses huise

tents tente

flats woonstelle

huts hutte

Which type of houses are the most? /
 Watse tipe huise is die meeste?

Which type of houses are the least? /
 Watse tipe huise is die minste?





English / Afrikaans

Possessive pronouns. / Besitlike voornaamwoorde.

Fill in the following pronouns: / Vul in die volgende voornaamwoorde:

theirs	hulle s'n	yours	joune
mine	myne	his	syne
hers	hare	ours	ons s'n

Week 6

Grade 1

1. I have a bicycle. The bicycle is

Ek het 'n fiets. Die fiets is

2. They have a bicycle. The bicycle is

Hulle het 'n fiets. Die fiets is

3. He has a bicycle. The bicycle is

Hy het 'n fiets. Die fiets is

4. You have a bicycle. The bicycle is

Jy het 'n fiets. Die fiets is

5. She has a bicycle. The bicycle is

Sy het 'n fiets. Die fiets is

6. We have a bicycle. The bicycle is

Ons het 'n fiets. Die fiets is

Match the pictures with a line./
Pas die prente bymekaar met 'n lyn

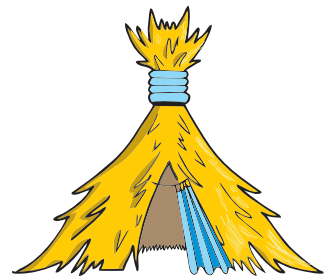
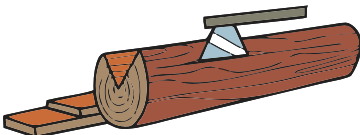
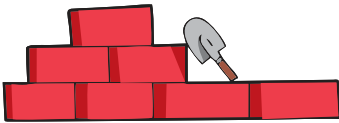
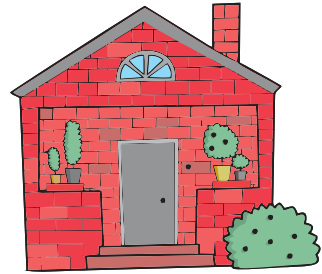

English / Afrikaans

Doubling./ Verdubbel.

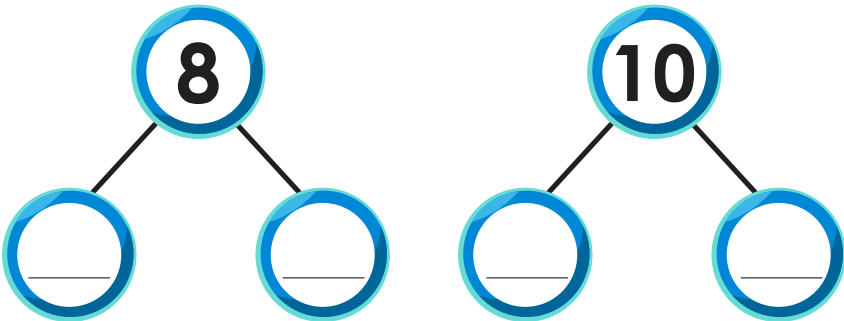
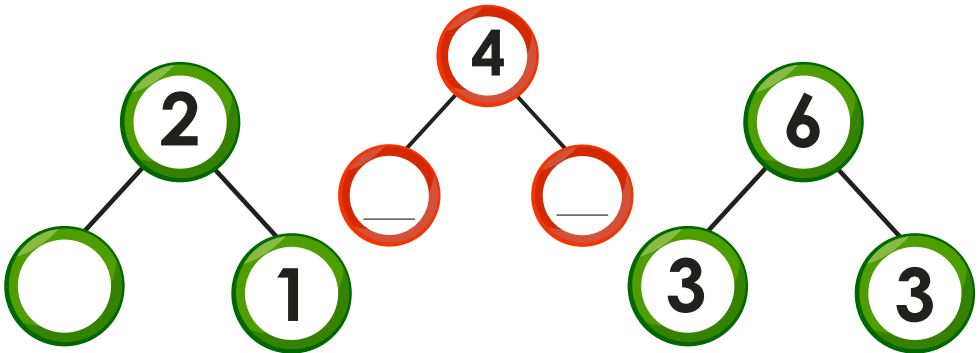
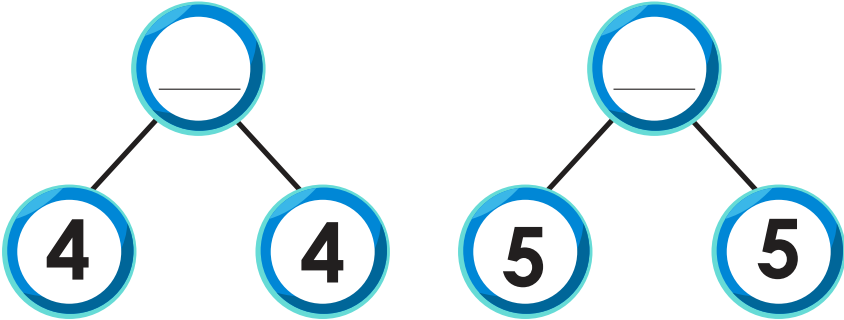
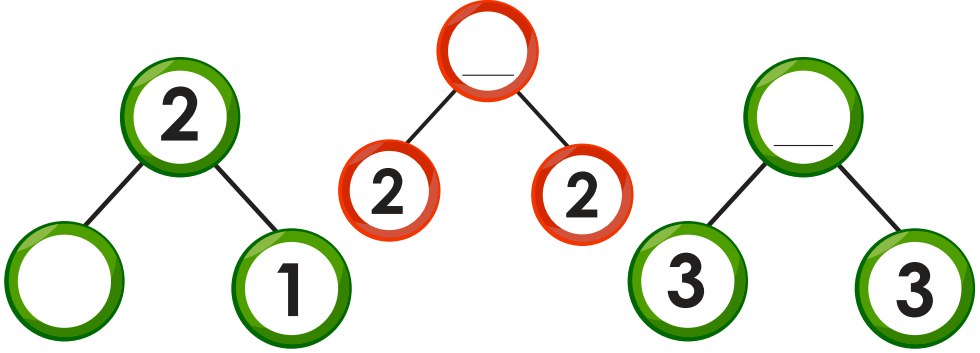

Grade 1 Week 6

English / Afrikaans

Sequencing./ Volgorde.

(Get ready for bed / Maak reg om te gaan slaap.)

Put these pictures in the right order to make a story.
Write 1, 2, 3, or 4 in the boxes.
Plaas die prente in die regte volgorde om 'n storie te maak.
Skryf 1,2,3, of 4 in die bokse.



Week 6

Grade 1

Light and Lighter. / Lig en Ligter.

Colour in the lightest object. / Kleur die ligste voorwerp in.

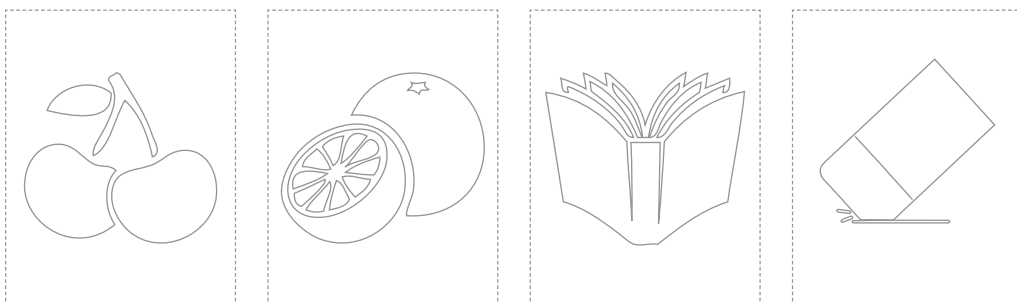
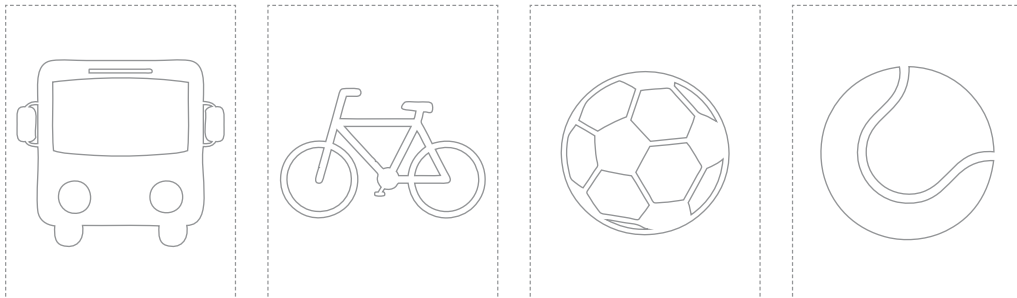

Circle the lightest object. / Omkring die ligste voorwerp.

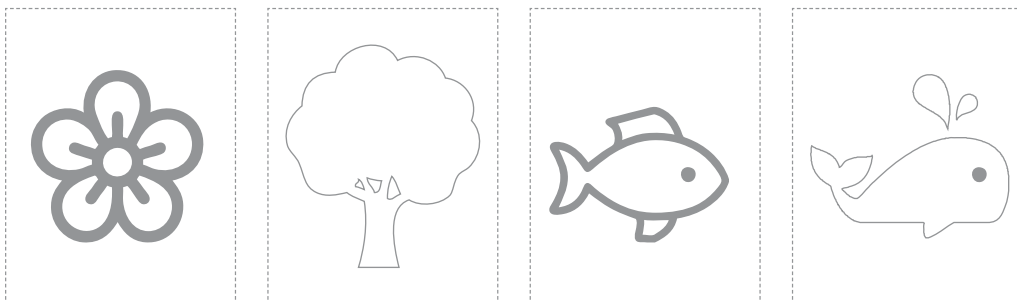
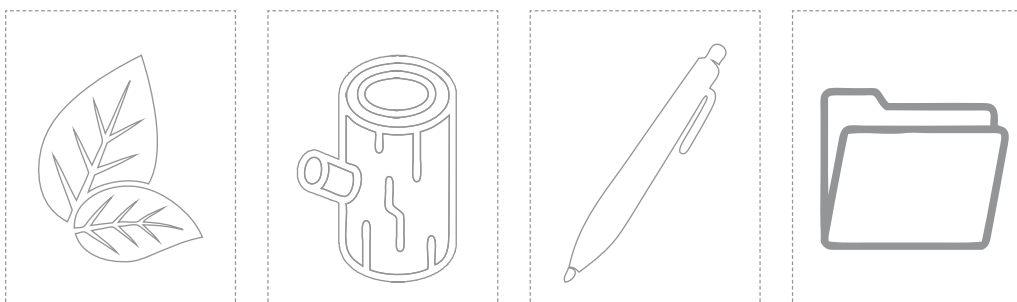

English / Afrikaans

Cut out and paste the pictures of a house. /
Knip en plak die prente van die huis.

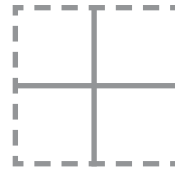
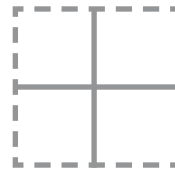
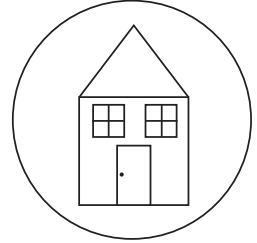
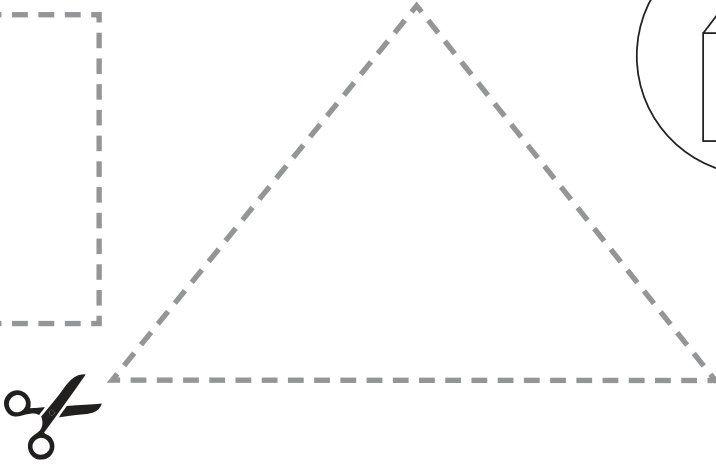
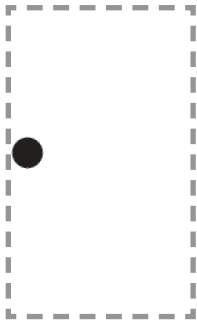

Week 6

Grade 1



1.5 metres





Success begins with education

Parents will be able to visit the website and watch daily videos or they can subscribe to our Zoshy Telegram channel to receive daily videos. One can also download the PDF version of the book on the website. Also watch our daily show on Active Kids to watch your favourite lessons.



<https://t.me/zoshyonline>



ONLINE

For extra perks!

How does it work?



Easy peasy steps to follow

Register at zoshy

You can save your favourite lessons and find them easier



- Step 1: Find us at www.zoshy.online or scan the QR code
- Step 2: Find your grade and select the year
- Step 3: Choose your language
- Step 4: Choose the week you want to learn out of
- Step 5: Choose lessons from what lessons there are
- Step 6: Download booklet if you do not have it
- Step 7: Watch and follow the teacher as she explains what to do in the book
- Step 8: Follow us on Facebook (Zoshy & Active Kids) to never miss a video
- Step 9: Subscribe to our Zoshy Telegram channel if you want to receive daily updates



www.zoshy.online

In collaboration with the Ministry of Education, Arts and Culture

PRINT

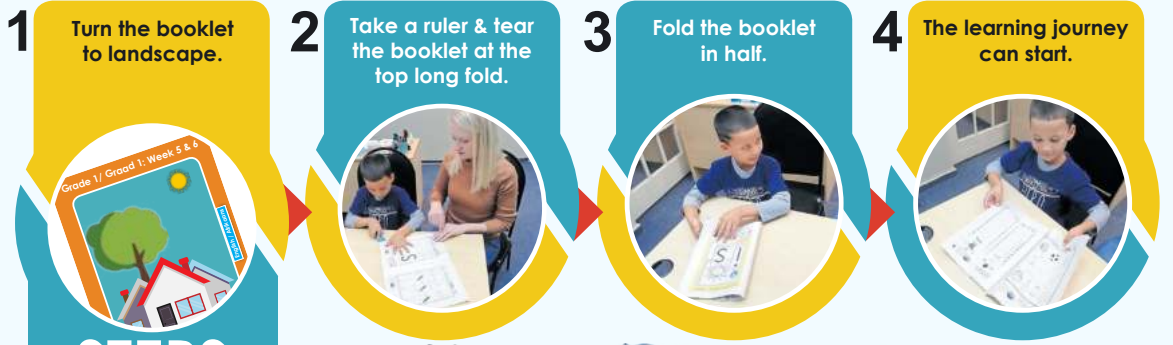

STEPS
HOW TO TEAR & USE
THE BOOKLET



DEAR SCHOOL REPRESENTATIVE



LANGUAGE INFORMATION SHEET



Namibia Media Holdings is committed to translate and distribute all Educational booklets for Pre-primary to Grade 3 in various languages. These languages will be printed and distributed in the coming weeks. To assist us, please complete the form below with information regarding your school, region, circuit, languages taught in each grade as well as the number of children per language. This will assist us in accurately distributing all languages across the country.

School: _____
School contact number: _____
School address: _____
Region: _____
Circuit: _____



Language	Amount of children per Grade for each language / Requested copies			
	Pre-primary	Grade 1	Grade 2	Grade 3
English				
Afrikaans				
German				
Khoekhoegawab				
Otjiherero				
Oshikwanyama				
Oshindonga				
Rukwangali				
Silozi				
Thimbukushu				
Other:				

Circuit officer, please provide your contact details below:

Name: _____
Contact number: _____
Address: _____



Signature.....